

Type UL

Type UL

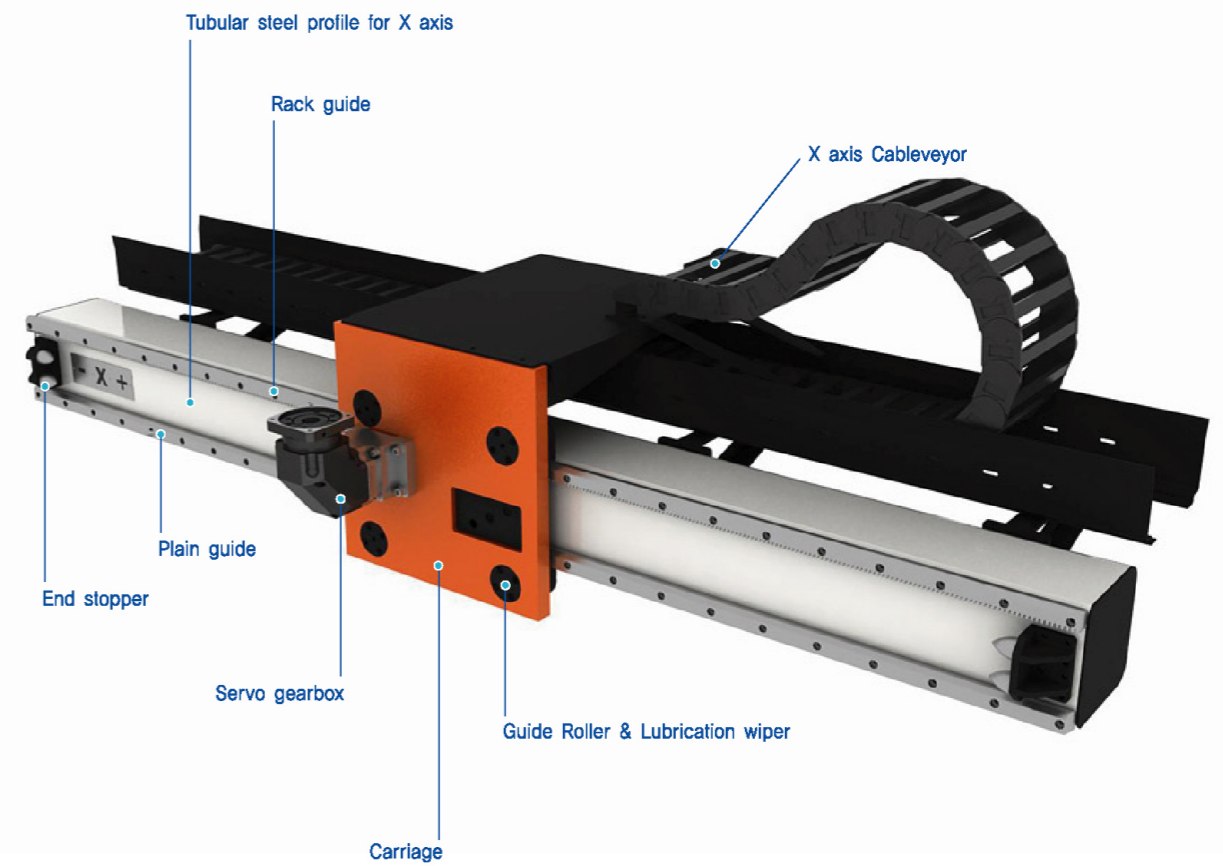

구분 / Module Type	가반하중 범위 / Payload range [kg]								
	60	80	100	120	150	200	250	400	
UL - 1	██								
UL - 2		██							
UL - 3				██					

UL

○ 제품치수 및 사양 | Dimension and specification

1축 리니어모듈 | 1 axis linear module

기술자료 UL-1 | Technical data UL-1

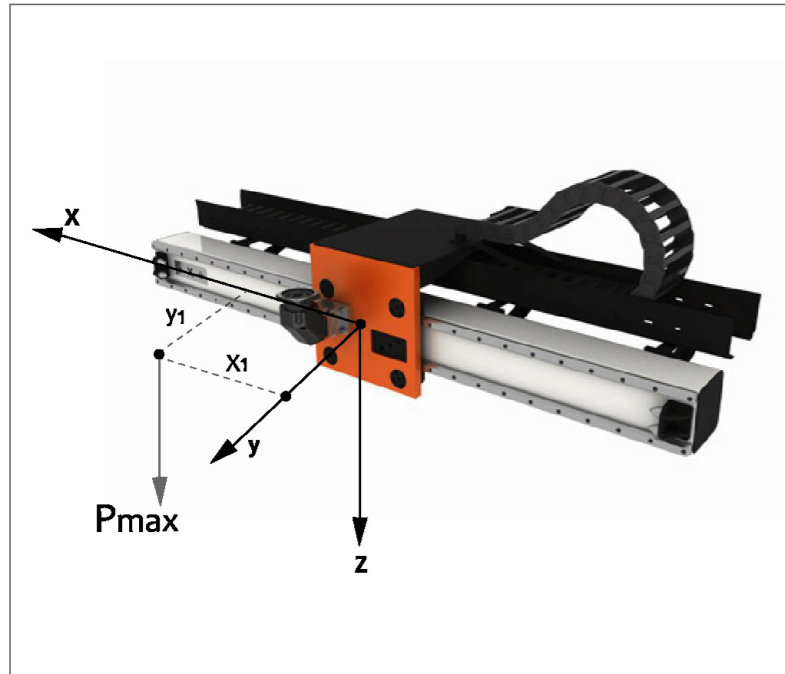

$P_{max} = 150kg$

P_{max} [kg] : 최대허용가능 가반하중
Permissible max. payload

P_{eff} [kg] : 유효 가반하중(그립퍼 포함)
Effective payload (incl. gripper unit)

$P_{eff} \leq P_{max}$ [kg]

$P_{max} = P_r$ [kg]

허용가반하중범위 | Payload range for loading position

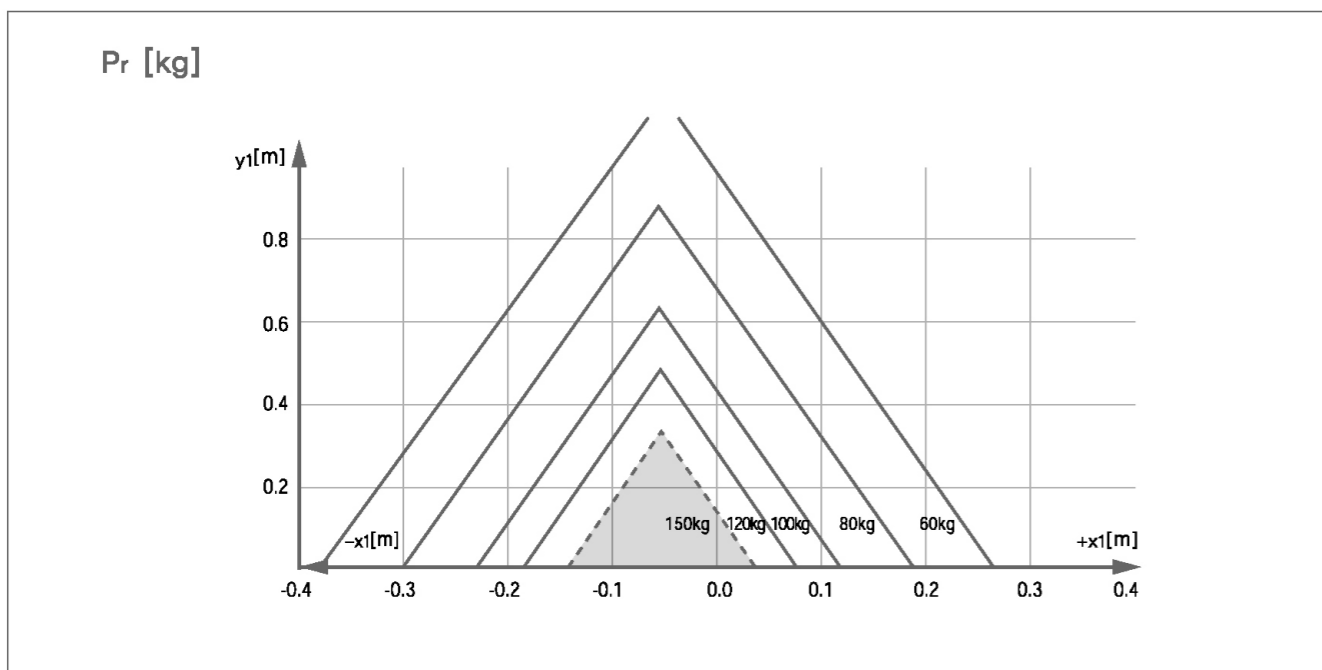

1축 리니어모듈 | 1 axis linear module

주요 구성부품 | Key component

No.	Description	Type	Unit weight	See page
1	가이드 롤러 / Guide roller	GR G 20	0,5 kg	24p
2	윤활 와이퍼 / Lubrication wiper	LW G 20	0,05 kg	28p
3	플레인 가이드 / Plain guide	MPG G 20	3,9 kg/m	20p
4	랙 가이드 / Rack guide	MRG G 20	3,8 kg/m	16p
5	감속기 / Gearbox	AFR075	6,4 kg	32p

부품상세사양은 부품카다로그를 참조하십시오.
Please refer to the component catalogue regarding detailed component specification

가반하중 및 작동사양 | Payload and drive data

Axis		X axis	
유효가반하중 / Effective payload	[kg]	60	100 150
공칭속도 / Nominal speed	[m/s]	2,6	2,6
최대가속도 / Max. acceleration	[m/s ²]	5	4 3
감속비 / Gearbox ratio	[-]	3:1	3:1 3:1
모터속도 / Motor speed	[rpm]	4500	4500 4500
반복정밀도 / Repeatability	[mm]		±0,05

굽힘 및 비틀림 저항 | Axis bending and torsion

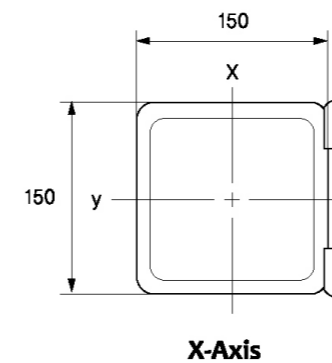

Axis	Material	Standard	Unit weight(kg/m)	Ix(cm ⁴)	Iy(cm ⁴)	It(cm ⁴)
X	R50	ISO 3304	58,5	2589	2387	3272

*가이드 부착시 / Guide assembly



○ 제품치수 및 사양 | Dimension and specification

1축 리니어모듈 | 1 axis linear module

치수 UL-1 | Dimensions sheet UL-1

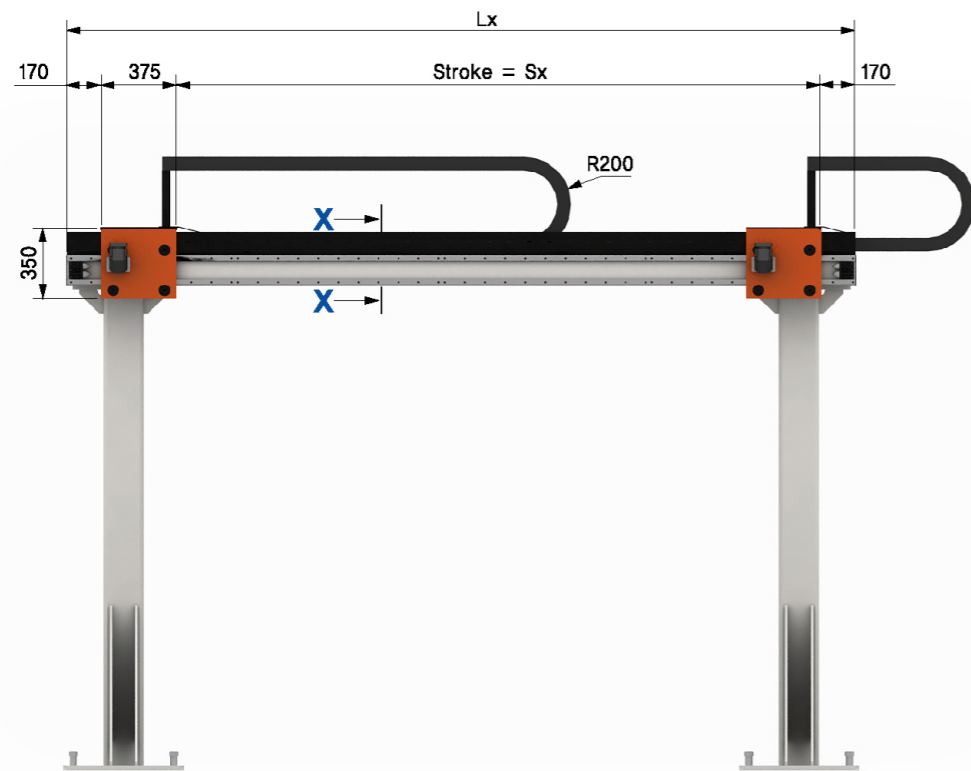

■ View X

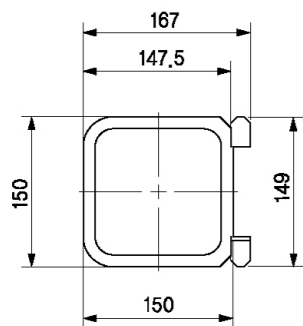

	max.(mm)
Lx	30715
Sx	30000

UL-1

1축 리니어모듈 | 1 axis linear module

치수 UL-1 | Dimensions sheet UL-1

■ View A

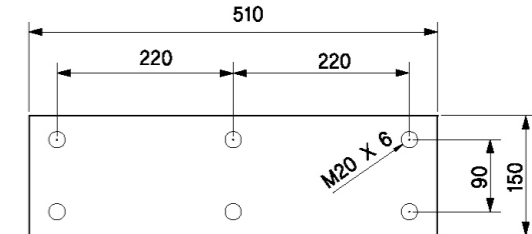

■ View B

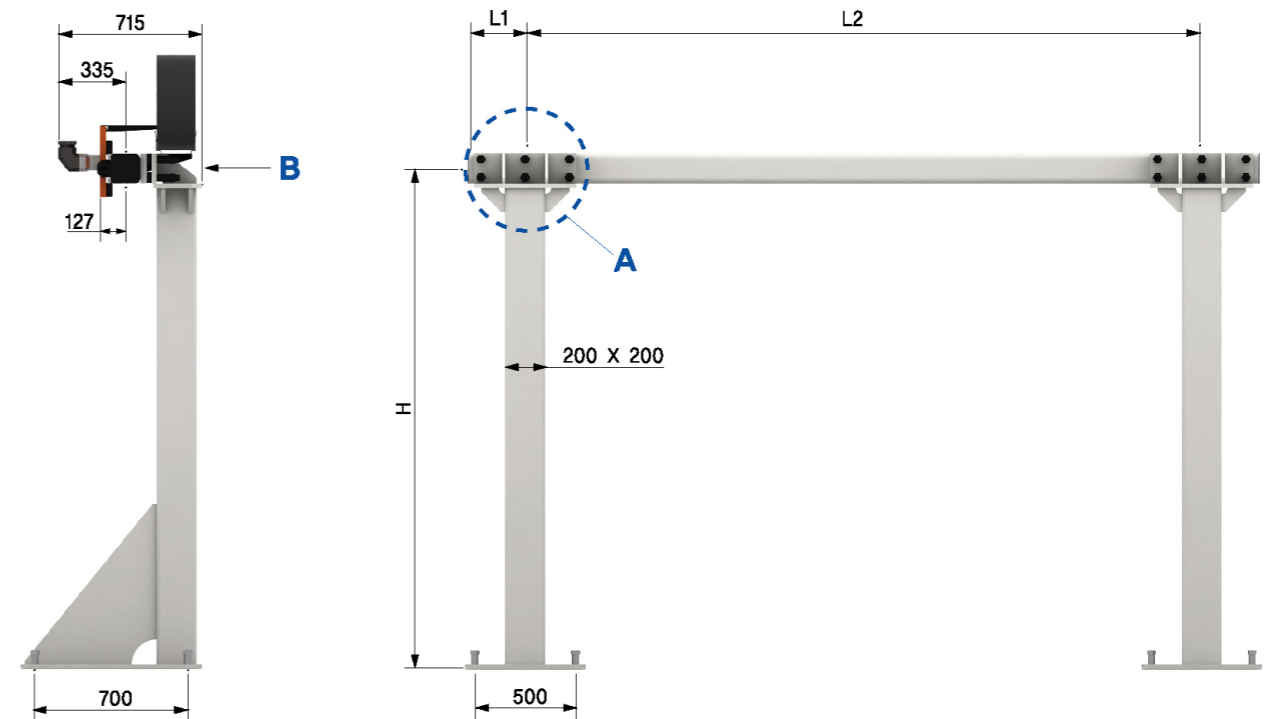

	min.(mm)	max.(mm)
L1	300	1500
L2	600	8000
H	900	3500

○ 제품치수 및 사양 | Dimension and specification

1축 리니어모듈 | 1 axis linear module

기술자료 UL-2 | Technical data UL-2

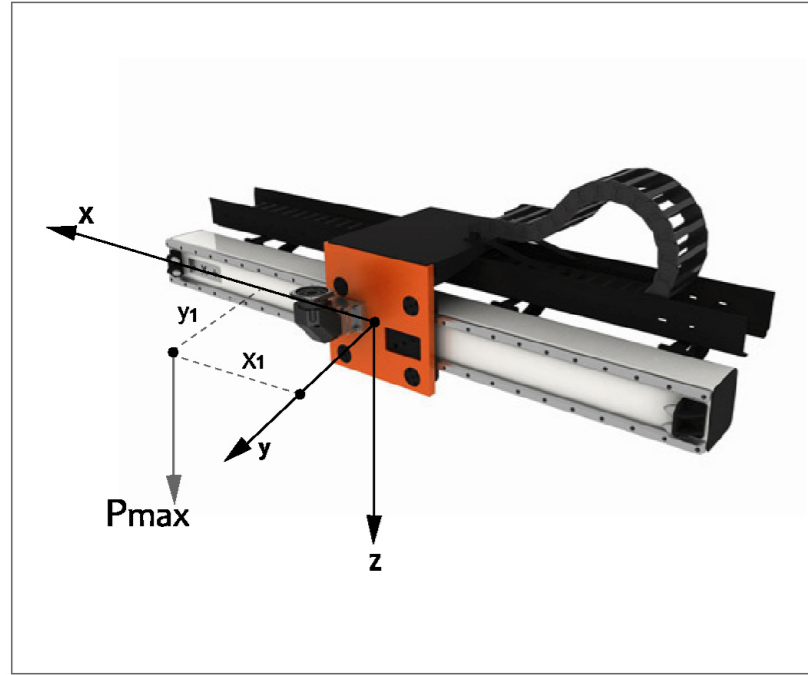

$P_{max} = 200kg$

P_{max} [kg] : 최대허용가능 가반하중
Permissible max. payload

P_{eff} [kg] : 유효 가반하중(그립퍼 포함)
Effective payload (incl. gripper unit)

$P_{eff} \leq P_{max}$ [kg]

$P_{max} = P_r$ [kg]

허용가반하중범위 | Payload range for loading position

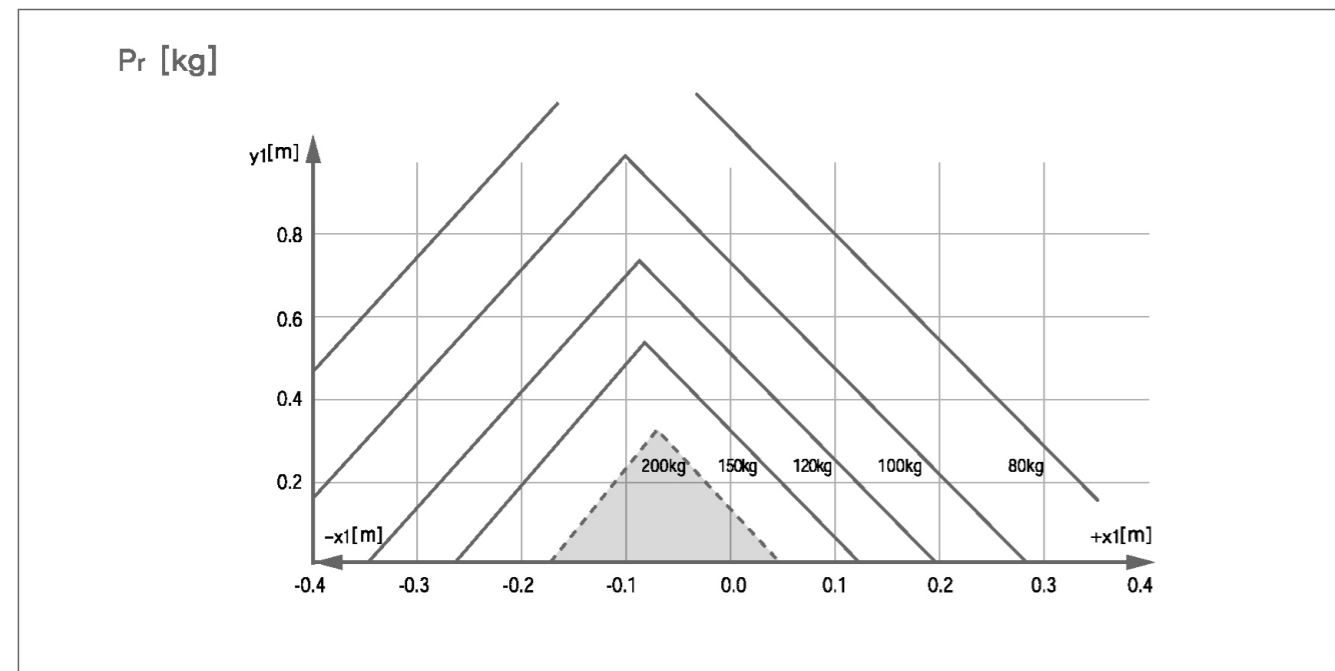

UL-2

1축 리니어모듈 | 1 axis linear module

주요 구성부품 | Key component

No.	Description	Type	Unit weight	See page
1	가이드 롤러 / Guide roller	GR G 25	1,1 kg	25p
2	윤활 와이퍼 / Lubrication wiper	LW G 25	0,13 kg	29p
3	플레인 가이드 / Plain guide	MPG G 25	5,7 kg/m	21p
4	랙 가이드 / Rack guide	MRG G 25	5,2 kg/m	17p
5	감속기 / Gearbox	AFR100	13,9 kg	33p

부품상세사양은 부품카다로그를 참조하십시오.
Please refer to the component catalogue regarding detailed component specification

가반하중 및 작동사양 | Payload and drive data

Axis		X axis	
유효가반하중 / Effective payload	[kg]	80	120
공칭속도 / Nominal speed	[m/s]	3	3
최대가속도 / Max. acceleration	[m/s ²]	7	6
감속비 / Gearbox ratio	[-]	3:1	3:1
모터속도 / Motor speed	[rpm]	3000	3000
반복정밀도 / Repeatability	[mm]		±0,05

굽힘 및 비틀림 저항 | Axis bending and torsion

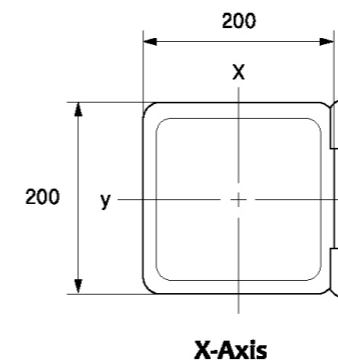

Axis	Material	Standard	Unit weight(kg/m)	Ix(cm ⁴)	Iy(cm ⁴)	It(cm ⁴)
X	R50	ISO 3304	80,5	6536	6106	8208

*가이드 부착시 / Guide assembly



○ 제품치수 및 사양 | Dimension and specification

1축 리니어모듈 | 1 axis linear module

치수 UL-2 | Dimensions sheet UL-2

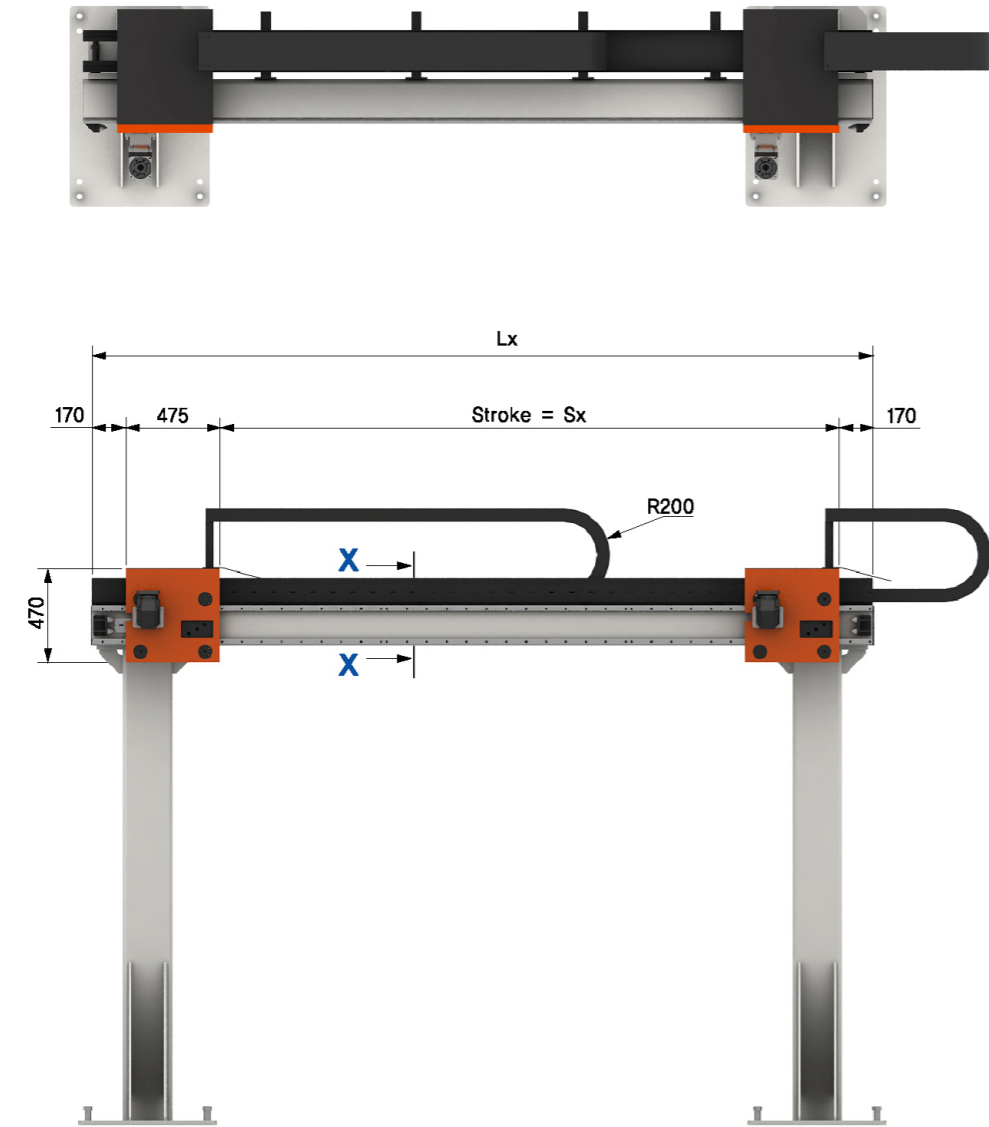

■ View X

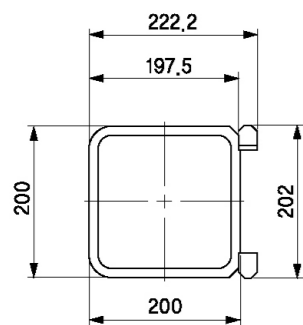

	max. value(mm)
Lx	50815
Sx	50000

UL-2

1축 리니어모듈 | 1 axis linear module

치수 UL-2 | Dimensions sheet UL-2

■ View A

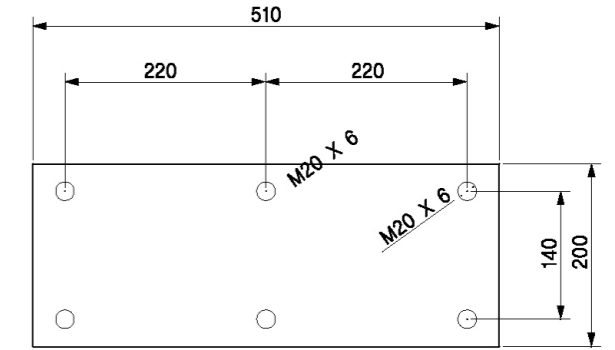

■ View B

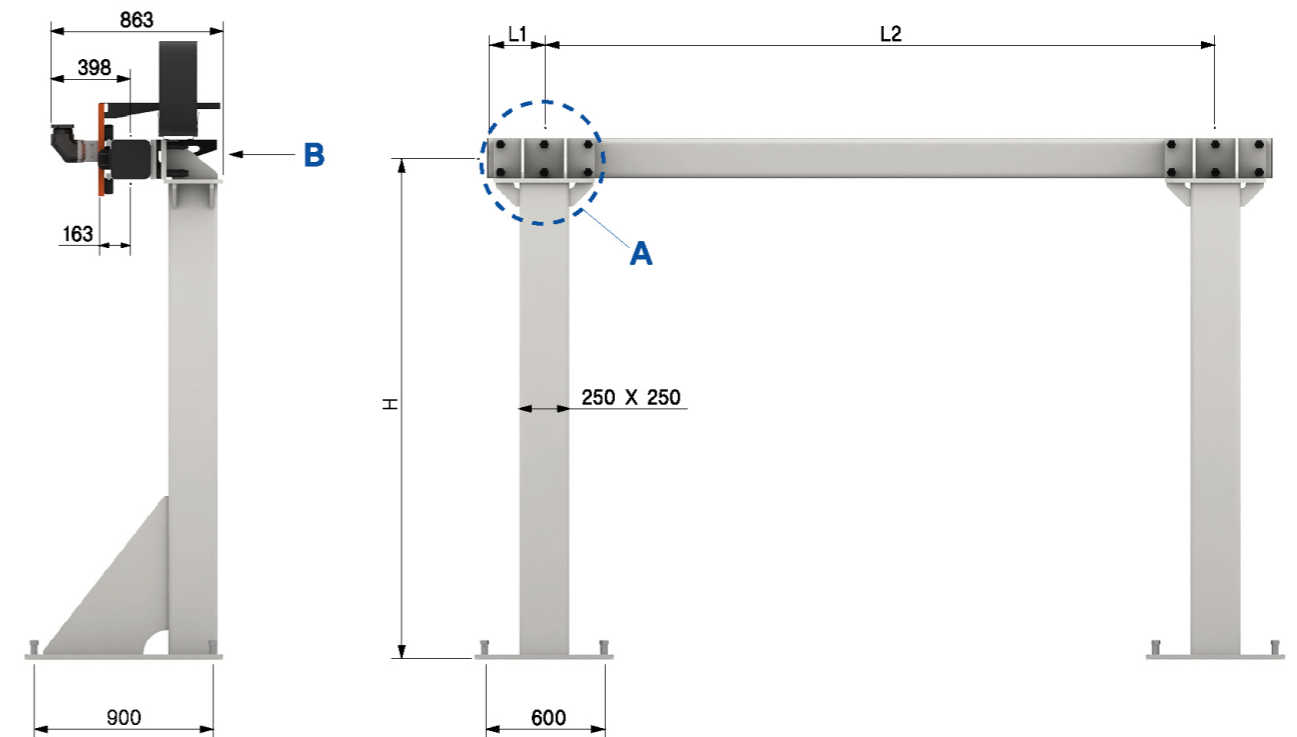

	min.(mm)	max.(mm)
L1	300	1500
L2	600	8000
H	900	4000

○ 제품치수 및 사양 | Dimension and specification

1축 리니어모듈 | 1 axis linear module

기술자료 UL-3 | Technical data UL-3

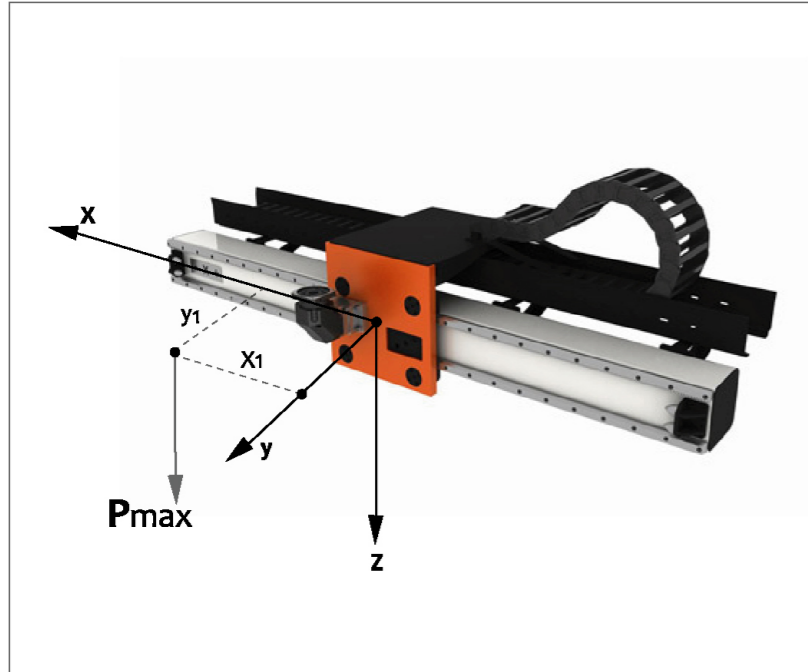

$P_{max} = 400\text{kg}$

P_{max} [kg] : 최대허용가능 가반하중
Permissible max. payload

P_{eff} [kg] : 유효 가반하중(그립퍼 포함)
Effective payload (incl. gripper unit)

$P_{eff} \leq P_{max}$ [kg]

$P_{max} = P_r$ [kg]

허용가반하중범위 | Payload range for loading position

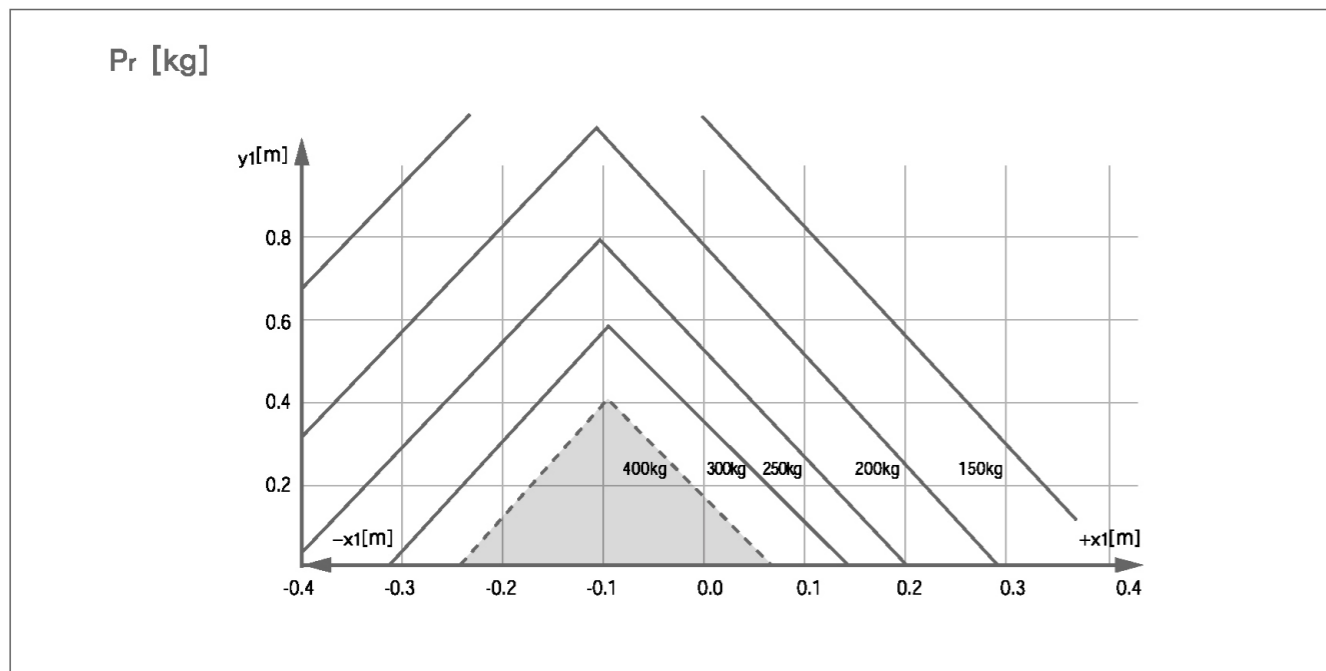

1축 리니어모듈 | 1 axis linear module

주요 구성부품 | Key component

No.	Description	Type	Unit weight	See page
1	가이드 롤러 / Guide roller	GR G 35	2,8 kg	26p
2	윤활 와이퍼 / Lubrication wiper	LW G 35	0,26 kg	30p
3	플레인 가이드 / Plain guide	MPG G 35	11,3 kg/m	22p
4	랙 가이드 / Rack guide	MRG G 35	10,6 kg/m	18p
5	감속기 / Gearbox	AFR140	23,7 kg	34p

부품상세사양은 부품카다로그를 참조하십시오.
Please refer to the component catalogue regarding detailed component specification

가반하중 및 작동사양 | Payload and drive data

Axis		X axis	
유효가반하중 / Effective payload	[kg]	150	250
공칭속도 / Nominal speed	[m/s]	3,3	3,3
최대가속도 / Max. acceleration	[m/s ²]	8	6
감속비 / Gearbox ratio	[-]	3:1	3:1
모터속도 / Motor speed	[rpm]	3000	3000
반복정밀도 / Repeatability	[mm]		±0,05

굽힘 및 비틀림 저항 | Axis bending and torsion

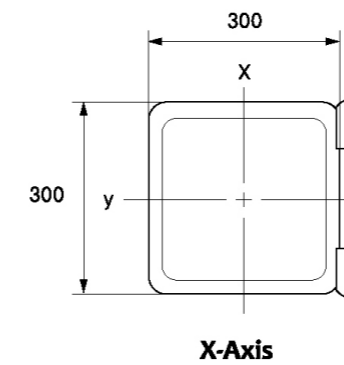

Axis	Material	Standard	Unit weight(kg/m)	Ix(cm ⁴)	Iy(cm ⁴)	It(cm ⁴)
X	R50	ISO 3304	162,9	29967	27894	37622

*가이드 부착시 / Guide assembly



○ 제품치수 및 사양 | Dimension and specification

1축 리니어모듈 | 1 axis linear module

치수 UL-3 | Dimensions sheet UL-3

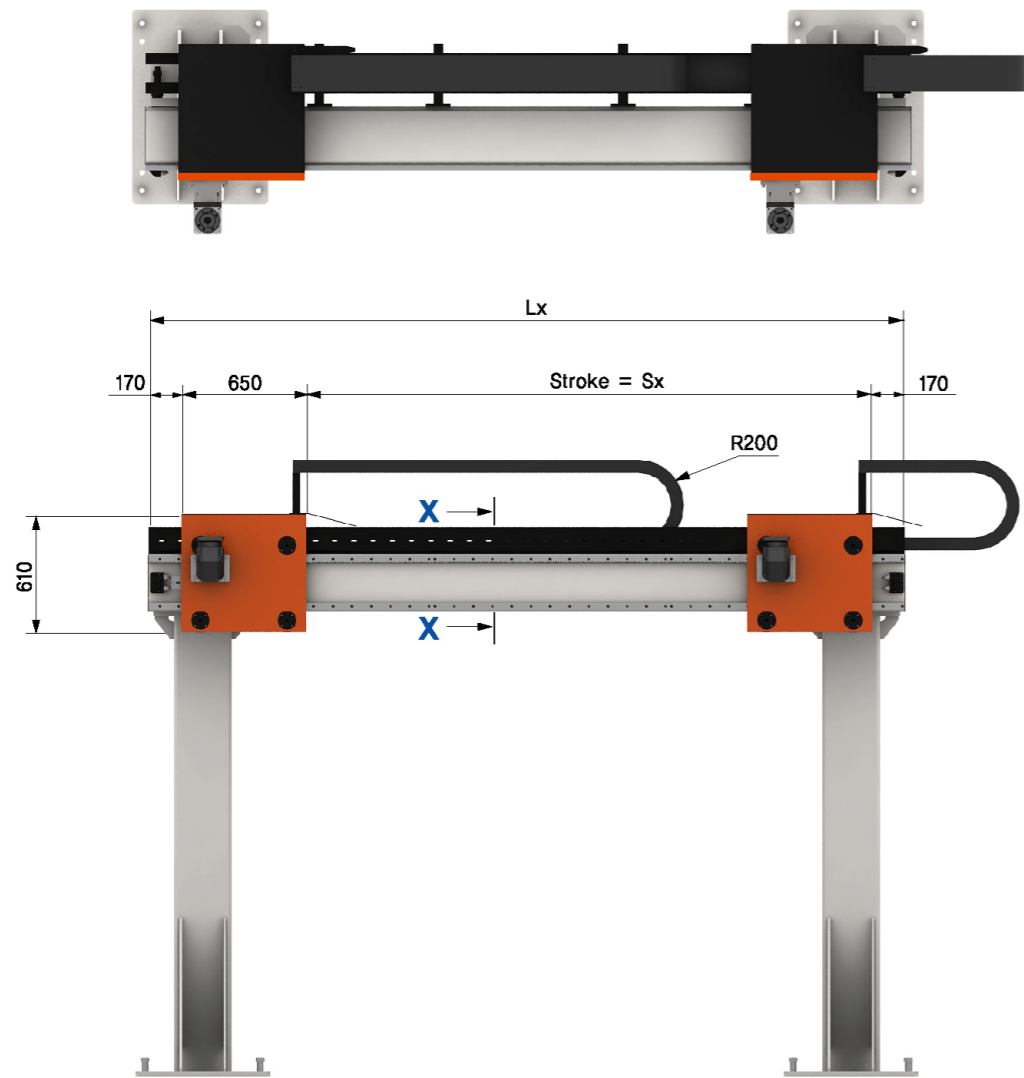

■ View X

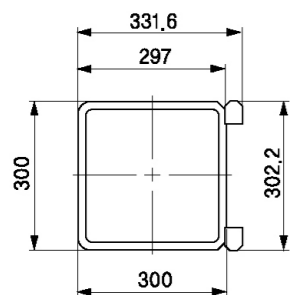

	max. value(mm)
Lx	80990
Sx	80000

UL-3

1축 리니어모듈 | 1 axis linear module

치수 UL-3 | Dimensions sheet UL-3

■ View A

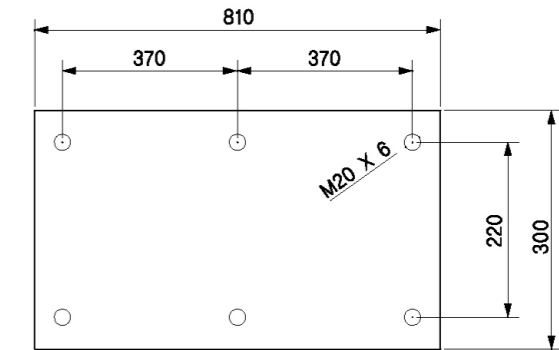

■ View B

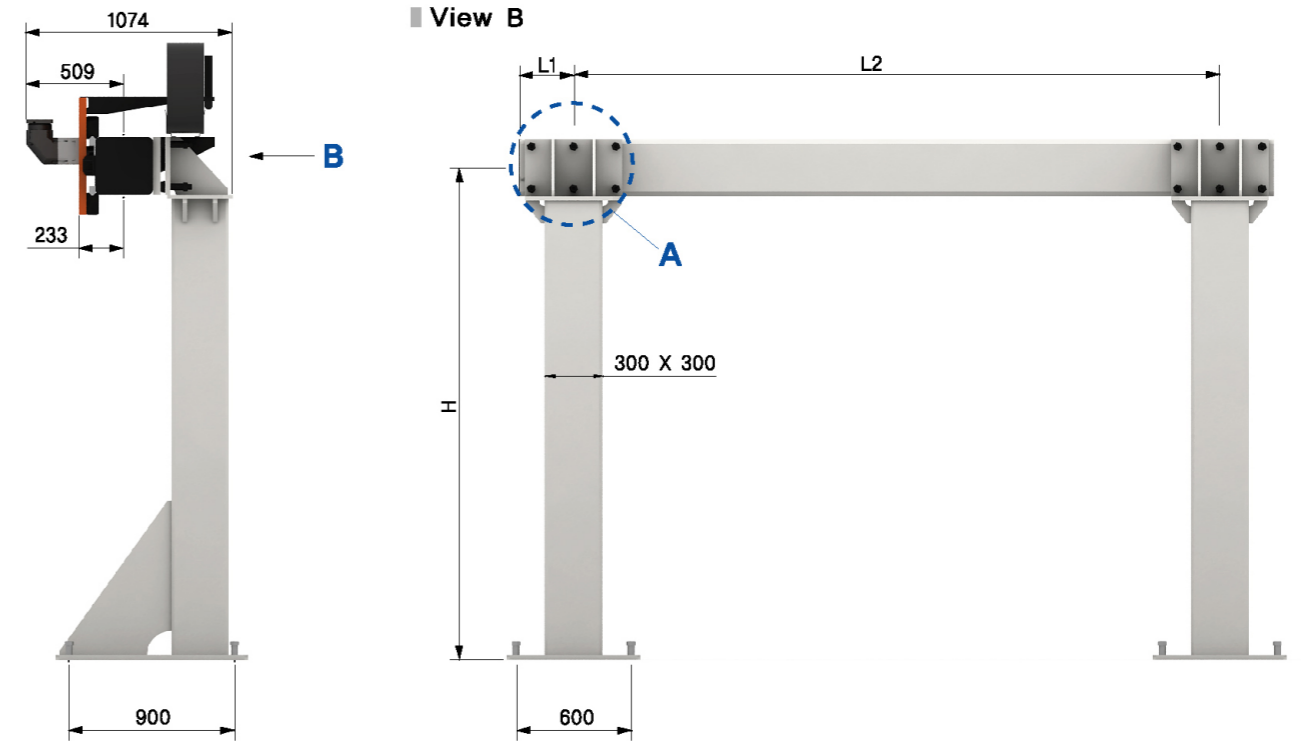

	min.(mm)	max.(mm)
L1	400	2000
L2	800	1000
H	1000	4000